

Drum Rotator - Crane Slung/Fork Mounted

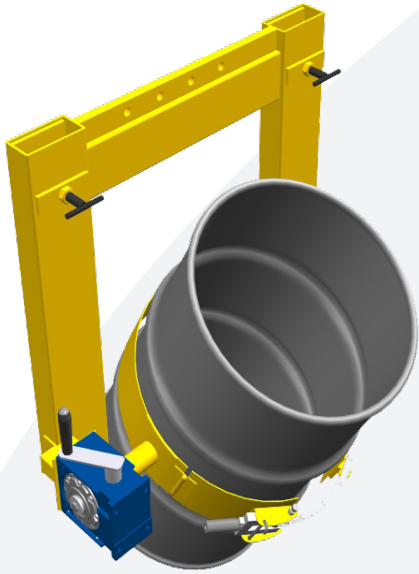

Universally flexible this rotator can either be mounted directly onto the truck forks via fork pockets or can be slung under a hook or crane. Ideal for use where trucks and emptying heights can be variable.

Will handle Steel or L ring plastic drums, this drum rotator allows a complete 360° rotation in either direction.

Rotation is achieved by means of a crank handle

Model Ref	Capacity (kg)	Method of Clamping	Max Fork Size (mm)	Drum Type (210 Litre)	Weight (kg)
DMR-1	360	Twin Harness	140 x 50	Steel & 'L' ring Plastic	134

Features & Benefits

- Universal lifting frame allows for both fork mounted and crane slung operation
- Twin ratchet & webbing strap allows for both 210L steel & L ring plastic drums to be handled
- High quality gear box enables smooth, controlled and precise pouring of drum contents
- Strong steel drum girdle ensures the drums are securely handled
- 'T' retention screws safely retains the attachment to the truck forks when fork mounted
- 'CE' marked and supplied with Certificate of Conformity for health & safety regulations



LIFTTRUCK
ATTACHMENTS

Albert Einsteinweg 5
NL-5151 DK
Drunen

Tel: +31(0)73- 640 00 52
www.ltabenelux.com
info@ltabenelux.com